

Urschel® Model CCX-D Dimensional Drawing

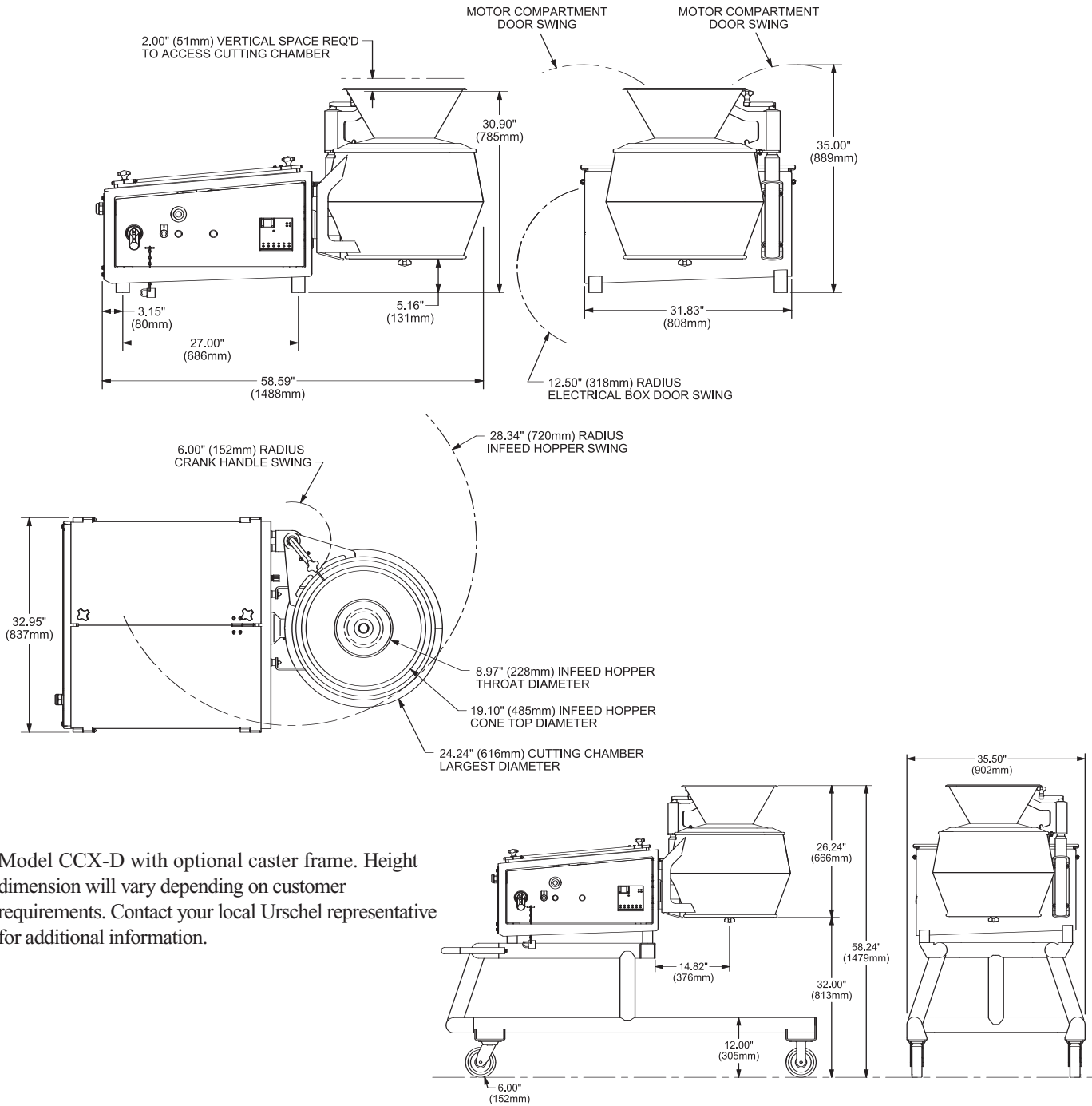

Model CCX-D with optional caster frame. Height dimension will vary depending on customer requirements. Contact your local Urschel representative for additional information.

Your Product Can Be Test Cut

Urschel Laboratories has a complete network of test facilities and experienced service and sales representatives around the world ready to work for you on any size reduction application. Contact your local Urschel Laboratories' representative to schedule a comprehensive, no-obligation test today at www.urschel.com



URSCHEL LABORATORIES INCORPORATED

2503 Calumet Avenue, P.O. Box 2200
Valparaiso, Indiana 46384-2200 U.S.A.
219/464-4811 Fax: 219/462-3879

<http://www.urschel.com>
E-mail: info@urschel.com

**Designers and manufacturers of
precision size reduction equipment.**